

CNC 2-Axes Lathe

TM 8i



mind over metalSM

HURCO[®]

Key Data



| | TM 8i |
|------------------------------------|-----------|
| Travels X / Z [mm] | 203 / 508 |
| Max. Turning Diameter [mm] | 256 |
| Main Spindle [kW / Nm] | 16 / 180 |
| Spindle Speed [min ⁻¹] | 4,800 |
| Stations | 12 |

Content

- [Technical Data](#)
- [Clearance Conditions](#)
- [Working Dimensions](#)
- [Shipping Dimensions](#)
- [Foundation Diagram](#)

Technical Data

| Machine Capacity | | Accuracy (VDI / DGQ 3441) | |
|--|-----------|---|---------------------|
| Travels X / Z [mm] | 203 / 508 | Positioning P _{max} [mm] | 0.01 |
| Max . Turning Diameter [mm] | 256 | Repeatability P _s [mm] | 0.005 |
| Max. Swing over Bed [mm] | 525 | Feedrates | |
| Over Cross Slide [mm] | 300 | Axis X / Z [m/min] | 19 / 24 |
| Spindle | | Turret | |
| Spindle Nose | A2-6 | Type | VDI 30 |
| Max. Speed [min ⁻¹] | 4,800 | Stations | 12 |
| Power max. / continous [kW] | 16 / 11 | Index Time [sec] | 0.5 |
| Torque max / continous [Nm] | 180 / 119 | Max. Boring Bar Diameter [mm] | 32 |
| Max Bar Size [mm] | 51 | Tool Shank Width [□ mm] | 19 |
| Chuck Diameter [mm] | 203 | Service Requirements/ Weight | |
| Acceleration 0 – 6,000 min ⁻¹ [sec] | 4,5 | Electrical | 22 kVA / 32A / 400V |
| Deceleration 6,000 – 0 min ⁻¹ [sec] | 7 | Air (Dry, clean air acc. DIN/ISO 8573-1, class 4) | 7bar / 150 l/min |
| Collet Type (optional) | CR60A6 | Weight [kg] | 4,500 |

[Back To Content](#)

*due to the position of the mass center of the machine, for unloading by forklift it is recommended to plan with a higher carrying capacity of 30%

Clearance Conditions

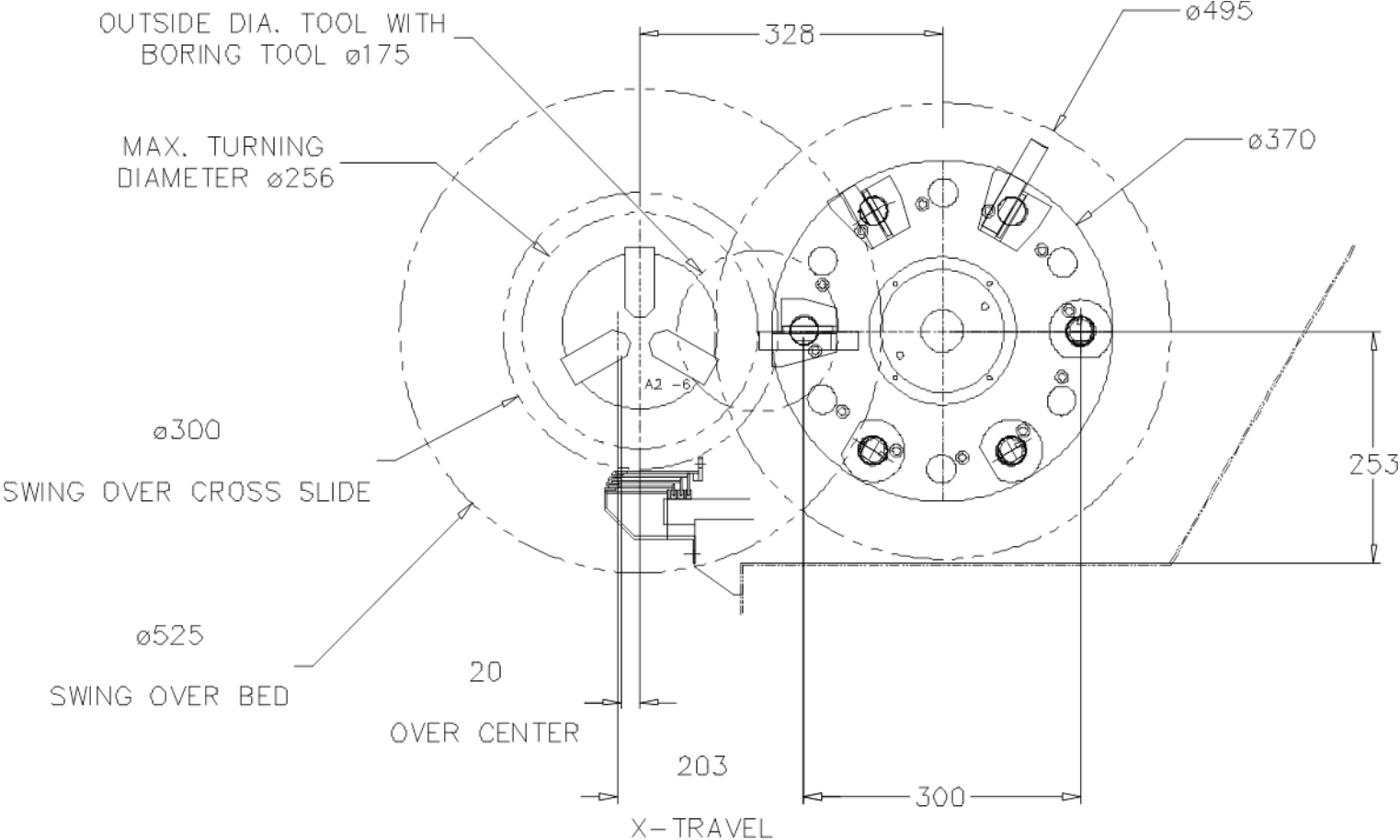

Clearance Conditions

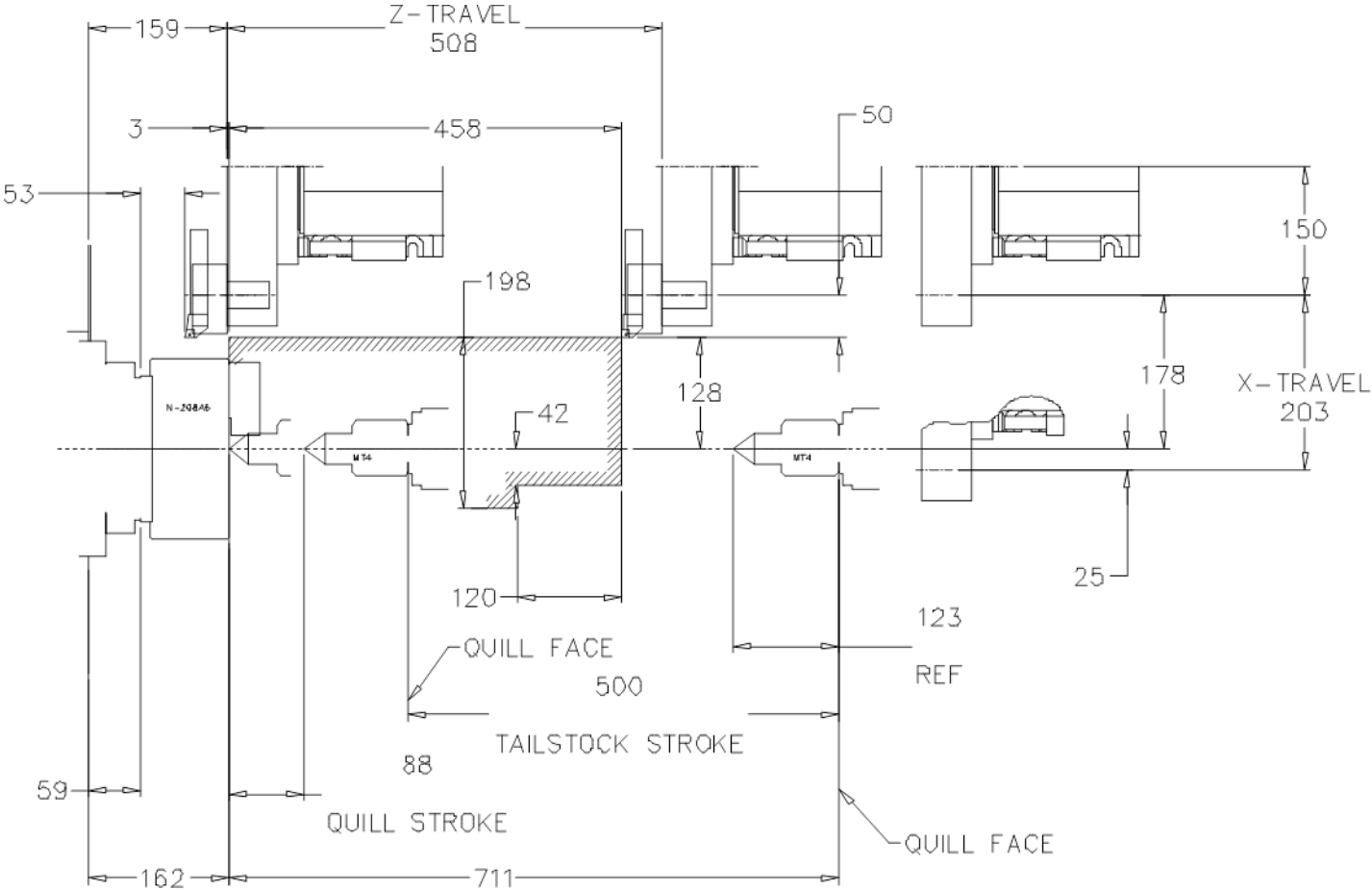

[Back To Content](#)

Working Conditions

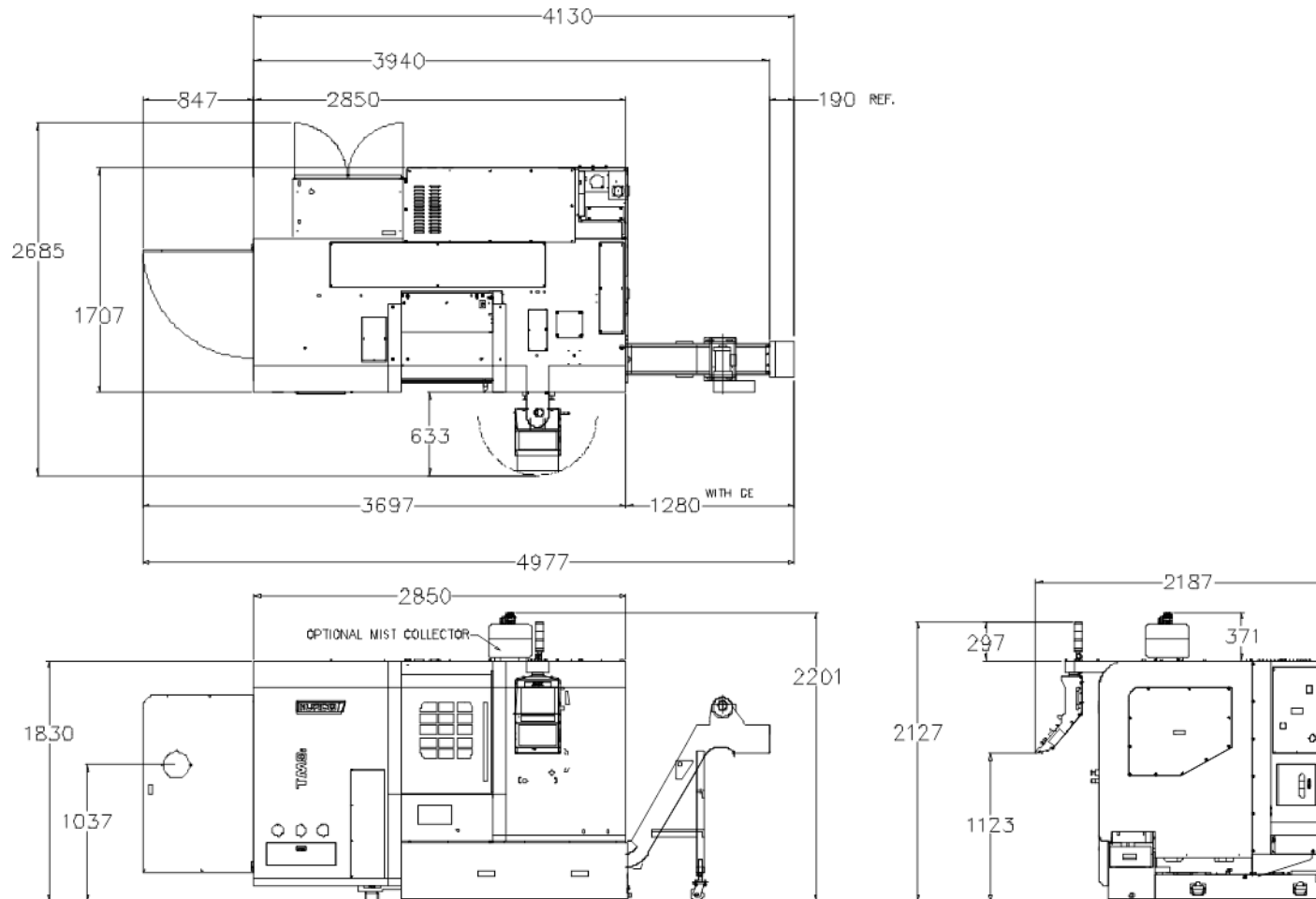

[Back To Content](#)

Shipping Dimensions

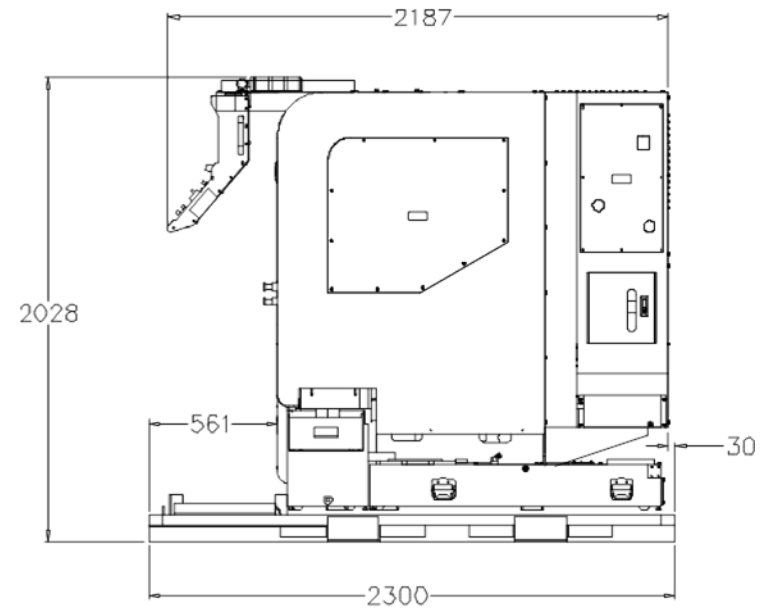
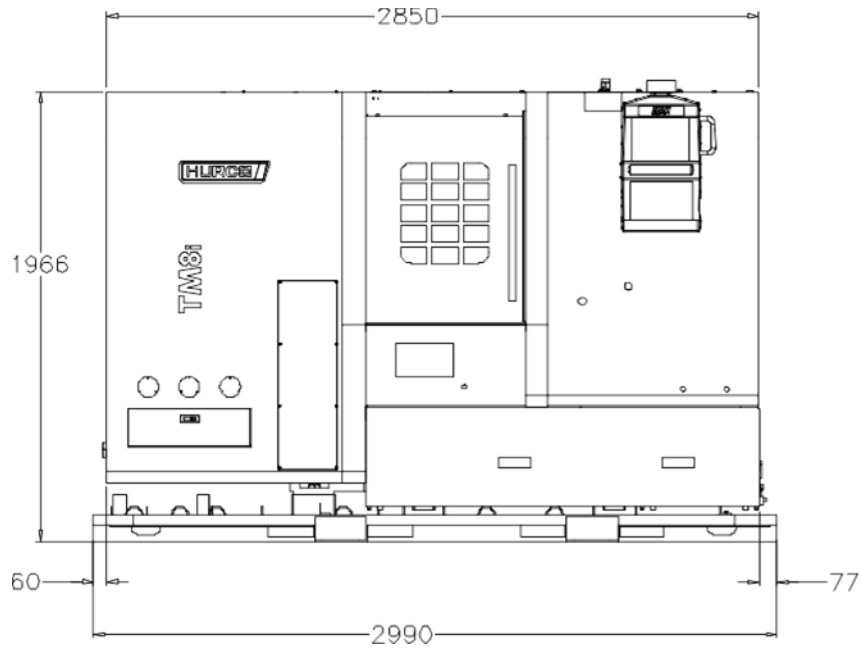

[Back To Content](#)



mind over metalSM

HURCO[®]