

CNC 2-Axes Lathe

# TM 18i



mind over metal<sup>SM</sup>

**HURCO**<sup>®</sup>

# Key Data



	TM18i
Travels X / Z [mm]	430 / 1015
Max. Turning Diameter [mm]	594
Spindle Power [kW]	55
Torque Gear Range 1 / 2 [Nm]	2415 / 604
Speed Gear Range 1 / 2 [min <sup>-1</sup> ]	600 / 1600
Turret Stations	12

# Content

- [Technical Data](#)
- [Clearance Conditions](#)
- [Working Dimensions](#)
- [Shipping Dimensions](#)
- [Foundation Diagram](#)

# Technical Data

Machine Capacity	
Travels X / Z [mm]	430 / 1015
Max . Turning Diameter [mm]	594
Max. Swing over Bed [mm]	850
Over Cross Slide [mm]	650
Spindle	
Spindle Nose	A2-15
Max. Speed [ $\text{min}^{-1}$ ]	600 / 1600
Power max. / continous [kW]	55 / 30
Torque max. / continous [Nm]	2415 / 1317
Gear Range 2	604 / 329
Max Bar Size [mm]	164
Chuck Diameter [mm]	455
Acceleration 0 – 600 $\text{min}^{-1}$ [sec]	3.5
Deceleration 600 – 0 $\text{min}^{-1}$ [sec]	8.0
Acceleration 0 – 1,600 $\text{min}^{-1}$ [sec]	5.0
Deceleration 1,600 – 0 $\text{min}^{-1}$ [sec]	5.0

Accuracy (VDI / DGQ 3441)	
Positioning $P_{\text{max}}$ [mm]	0.01
Repeatability $P_S$ [mm]	0.005
Feedrates	
Axis X / Z / autom. movable Tailstock [m/min]	20 / 20 / 2.4
Turret	
Type	VDI 50
Stations	12
Index Time [sec]	1.5
Max. Boring Bar Diameter [mm]	50
Tool Shank Width [ □ mm]	32
Service Requirements/ Weight	
Electrical	62.5 kVA / 90 A / 400V
Air (Dry, clean air acc. DIN/ISO 8573-1, class 4)	7bar / 150 l/min
Weight [kg]	11,500
Shipping weight [kg]	15,000

[Back To Content](#)

\*due to the position of the mass center of the machine, for unloading by forklift it is recommended to plan with a higher carrying capacity of 30%

# Clearance Conditions

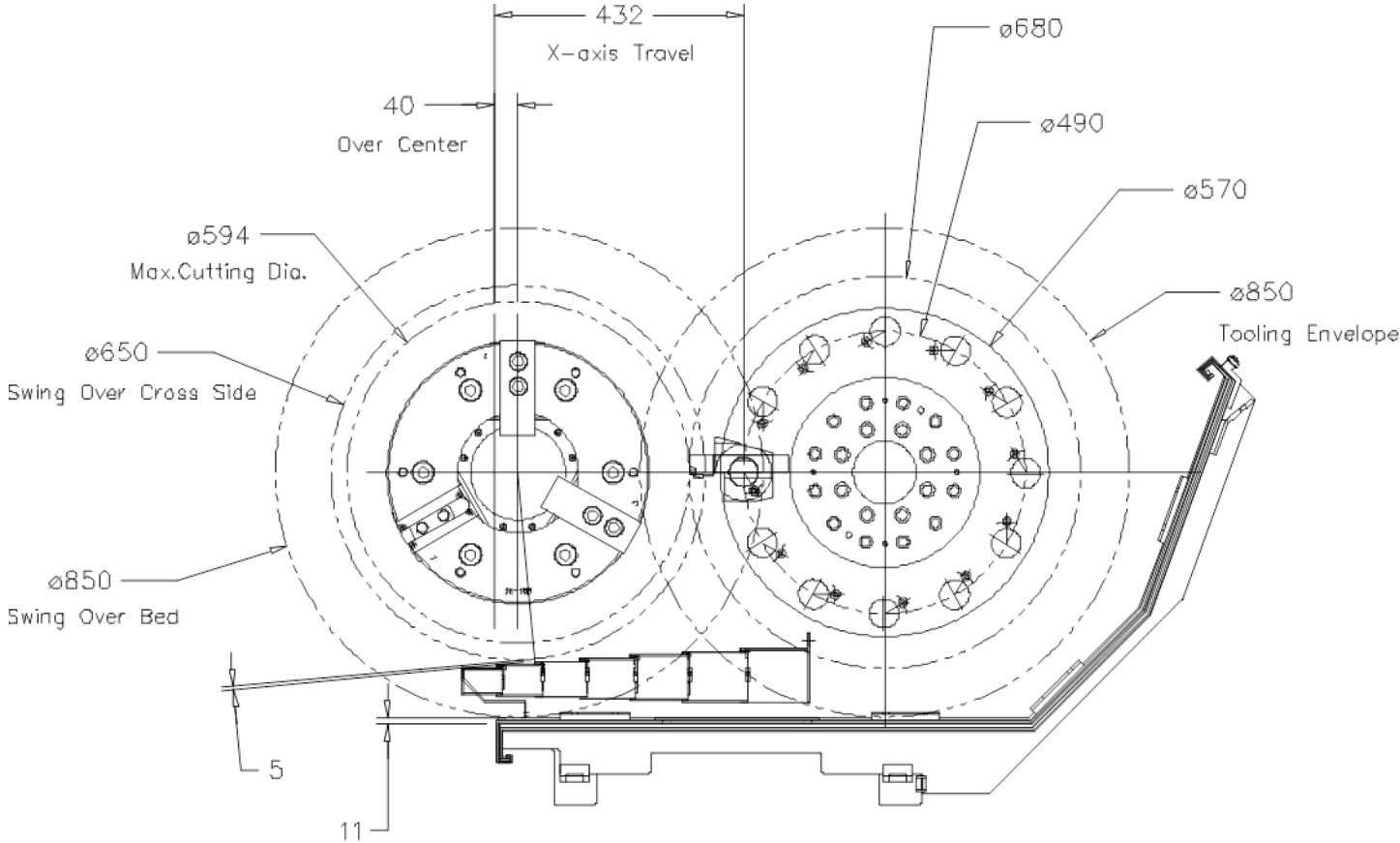

# Clearance Conditions

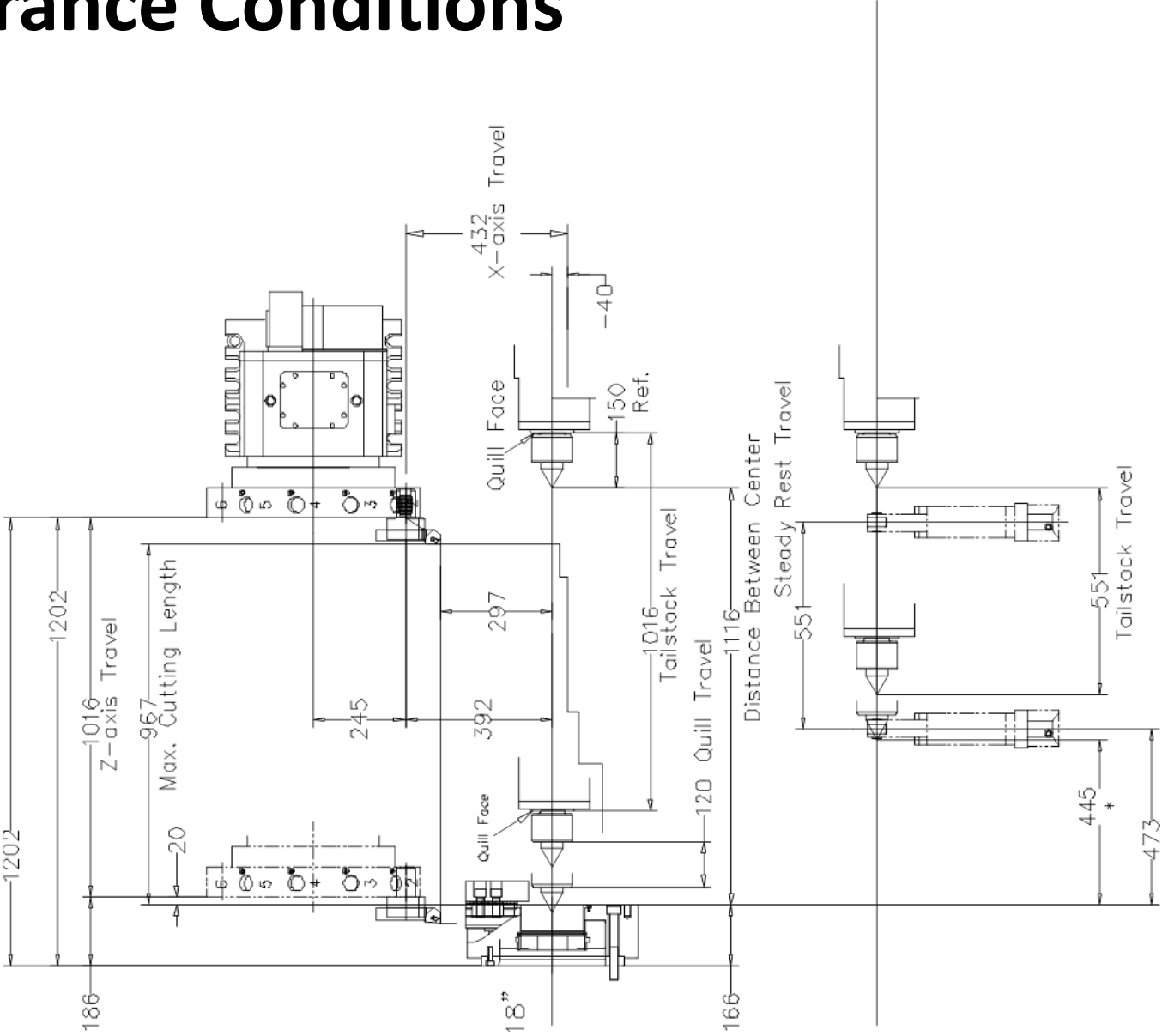

[Back To Content](#)

# Working Conditions

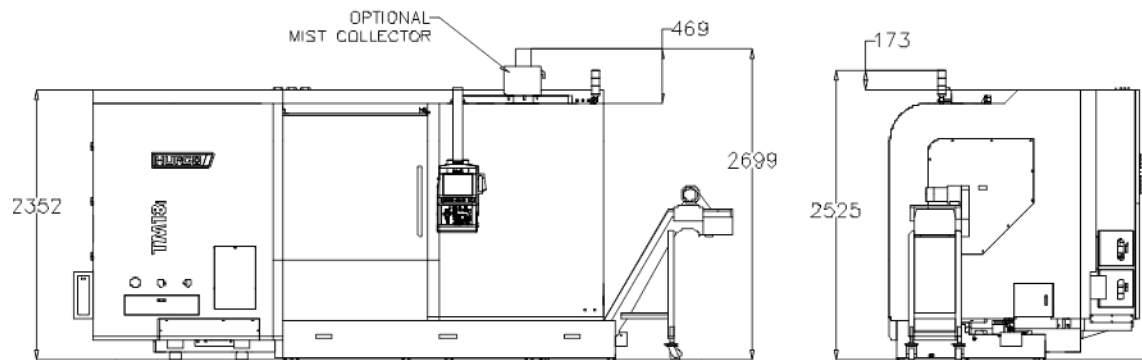
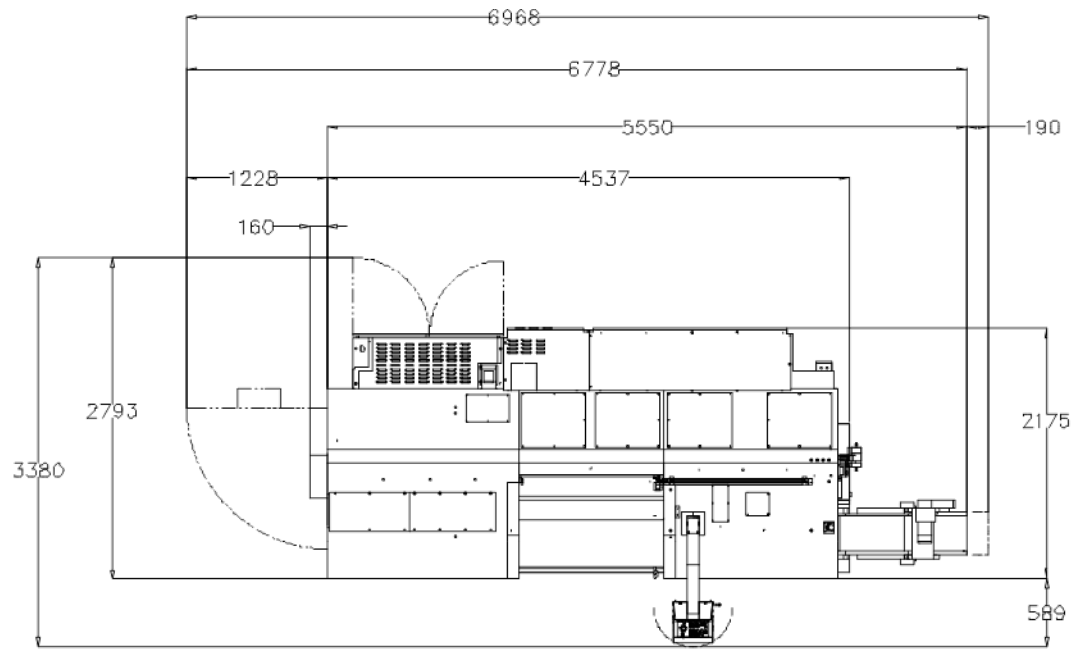

[Back To Content](#)

# Shipping Dimensions

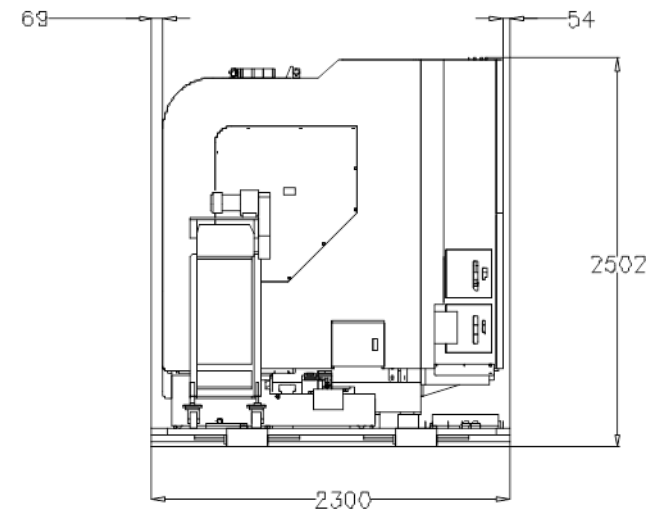
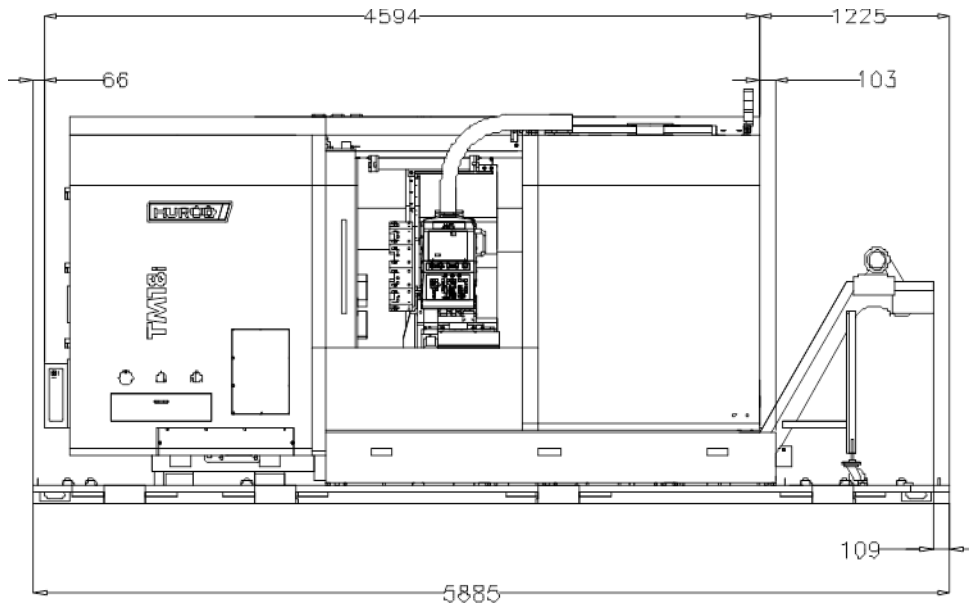

[Back To Content](#)



# Foundation Diagram

[Back To Content](#)



mind over metal<sup>SM</sup>

**HURCO**®